

SWISS POWER

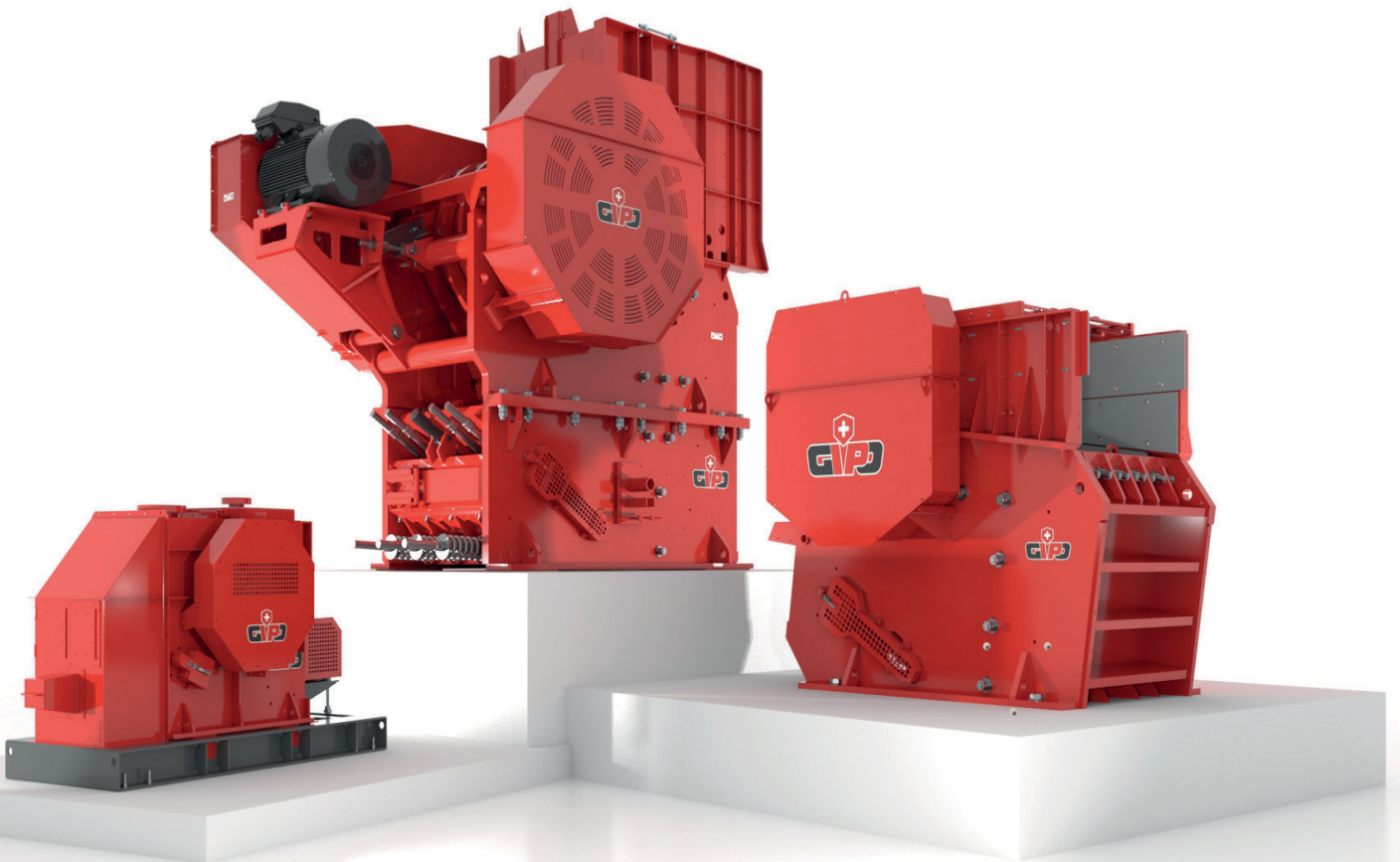

JAW CRUSHERS



JAW CRUSHERS – PROVEN STRENGTH

The jaw crushers from GIPO AG are based on many years of experience in the planning and production of processing systems. Our sophisticated designs, combined with high-quality materials, ensure extraordinary robustness and reliability. GIPO jaw crushers are characterised above all by an optimal relationship between feed material lump size and crusher weight/size. Thanks to mature crusher technology, the crushing performance is exceptionally high – even for very hard materials. Whether hard, abrasive natural stone or recycled construction material, jaw crushers from GIPO offer the optimal solution for every task.

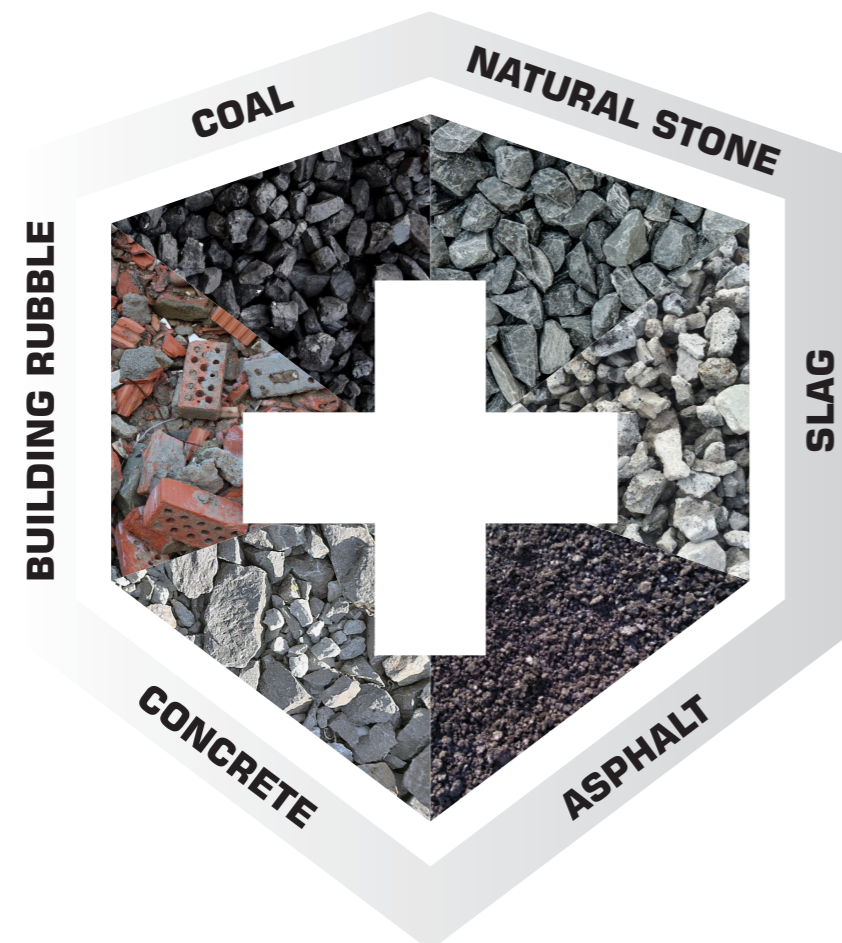

“ THE OPTIMAL SOLUTION FOR EVERY TASK ”

PRIMARY JAW CRUSHERS
ROBUST – PROVEN – INDESTRUCTIBLE

The primary jaw crusher is the ideal machine for harsh applications and is proven as a pre-crusher for crushing medium-hard to hard rock and minerals. GIPO primary crushers perform reliably even with the highest loads. The combination of the crusher inlet angle between the fixed and moving crushing jaw, the jaw length and the ideal eccentric stroke is tuned to the highest crushing performance – also with very difficult feed material. These features ensure cost-efficient crushing with low wear.

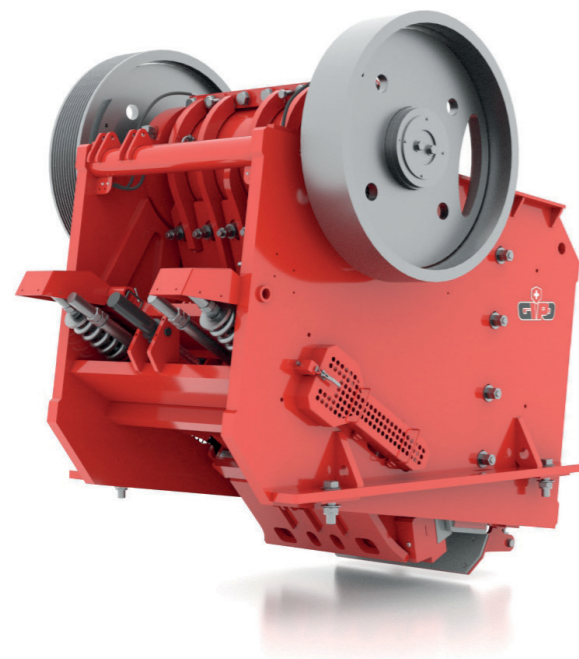
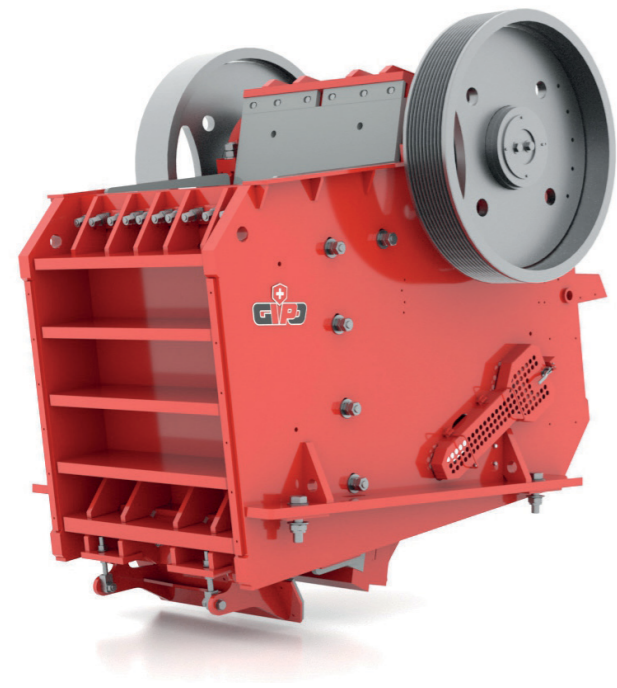

"HIGH PERFORMANCE IN TUNNELS"

Our GIPO jaw crushers deliver maximum efficiency and reliability even under the toughest conditions in tunnelling. They are robust, powerful and work with precision – perfectly matched to the requirements of each project.



JANEK METTLER
GIPO AG

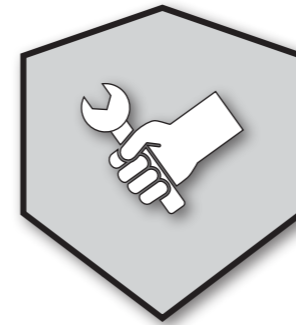

COST-EFFECTIVE

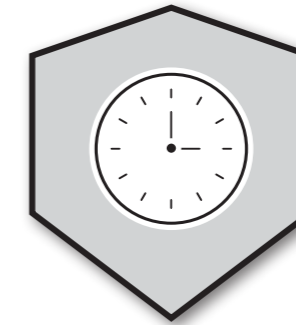

RELIABLE



POWERFUL

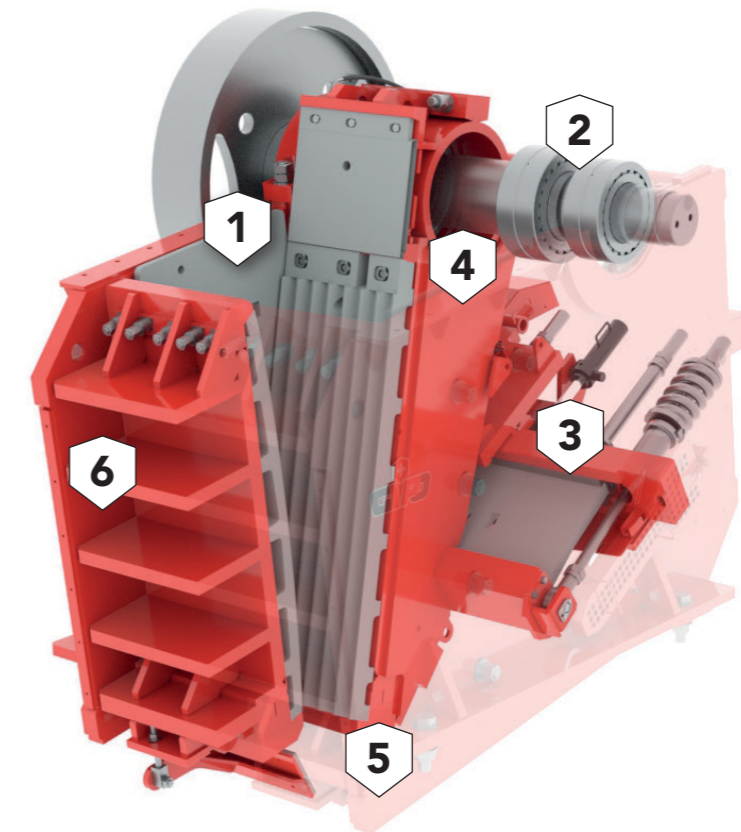

- 1** Crusher inlet
- 2** Crushing arm bearings
- 3** Crushing gap adjustment
- 4** Crushing arm
- 5** Crushing jaw support
- 6** Crushing housing

SECONDARY CRUSHER
POWERFUL – COMPACT – RESILIENT

The secondary crusher from GIPO is primarily used as a post-crusher. It is the optimal solution for processing hard, abrasive feed material. The GIPO secondary crusher efficiently crushes the pre-crushed rock into high-quality ballast and chippings with the required particle quality. Thanks to the special shape and arrangement of the crushing jaws, this post-crusher impresses with its high throughput.

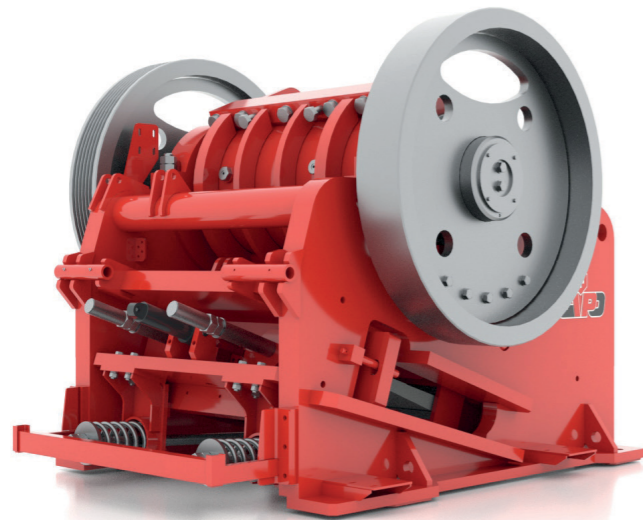
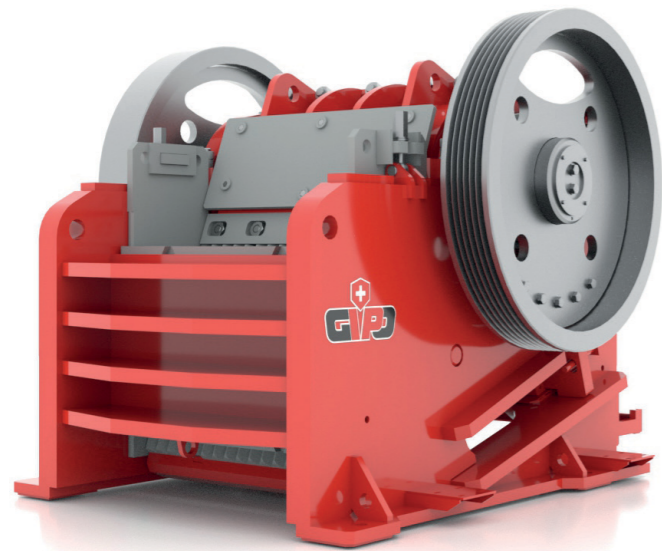

**“STURDY,
 DURABLE
 DESIGN”**

The sturdy, generously dimensioned design is the perfect prerequisite for crushing hard rock. The jaw crusher NB 1035 is the ideal tool for us with its high throughput and low wear.



MICHELA GASPERINI
HARTSTEINWERK GASPERINI AG

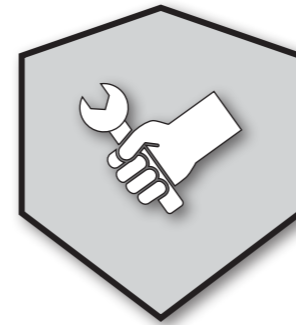

ROBUST

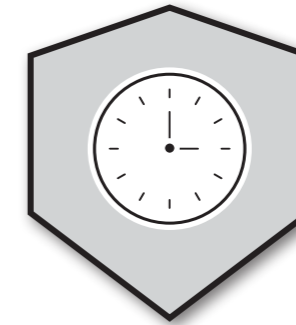

DURABLE

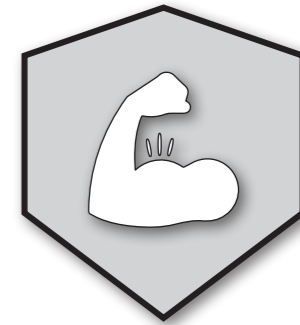

POWERFUL

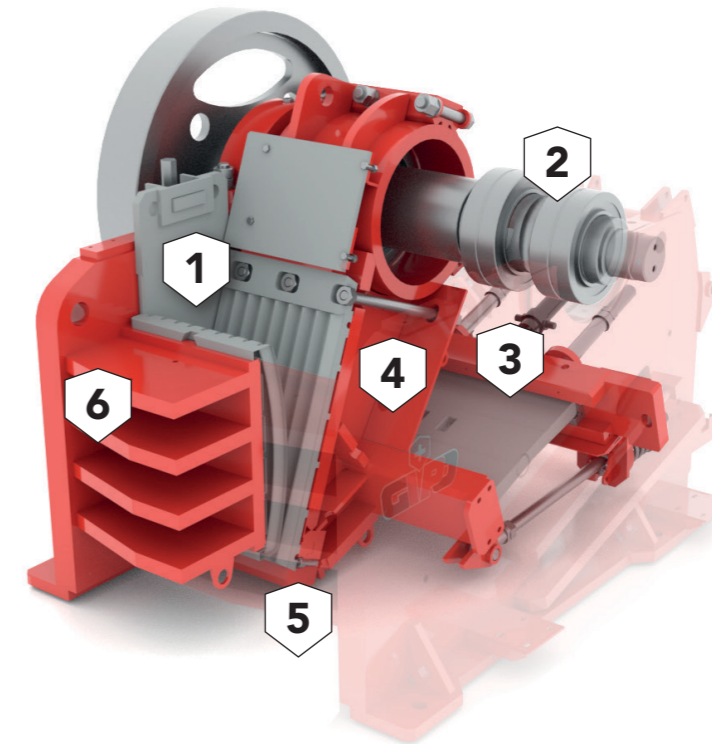

- | | |
|----------------------------------|-------------------------------|
| 1 Crusher inlet | 4 Crushing arm |
| 2 Crushing arm bearings | 5 Crushing jaw support |
| 3 Crushing gap adjustment | 6 Crushing housing |



MAIN FEATURES



1

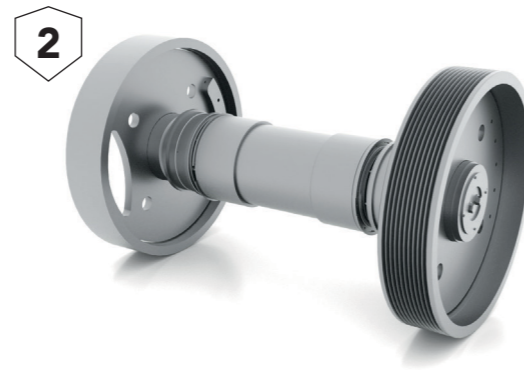

2

4

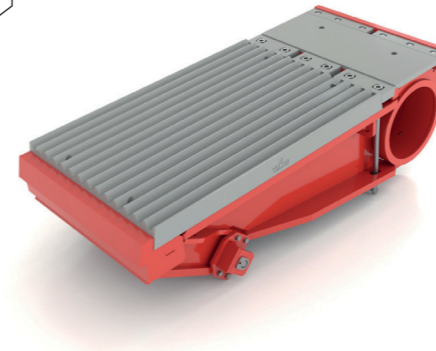

5

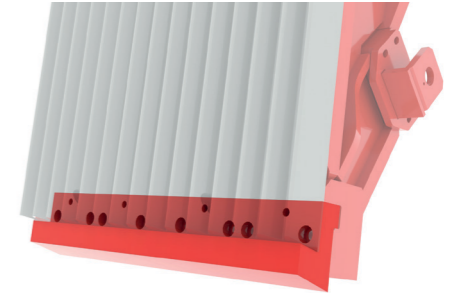

3

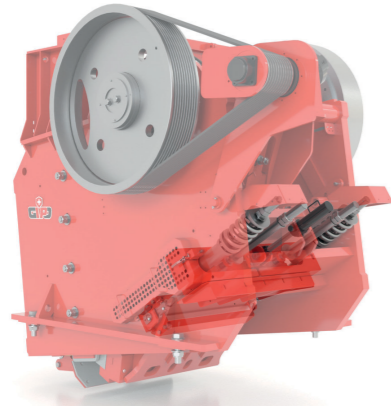

3

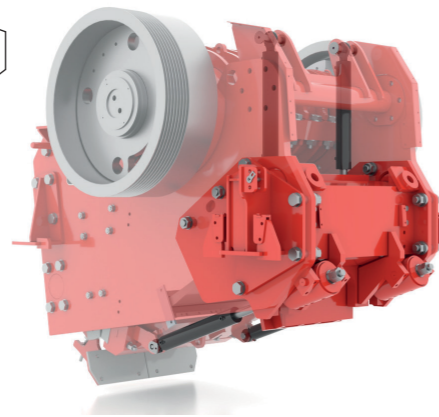

6

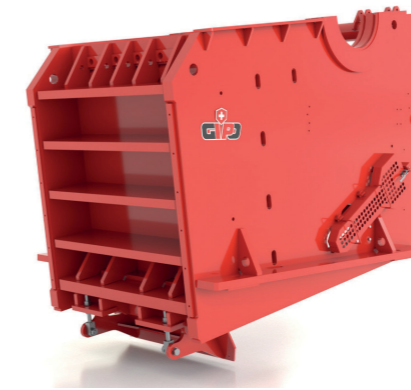

6

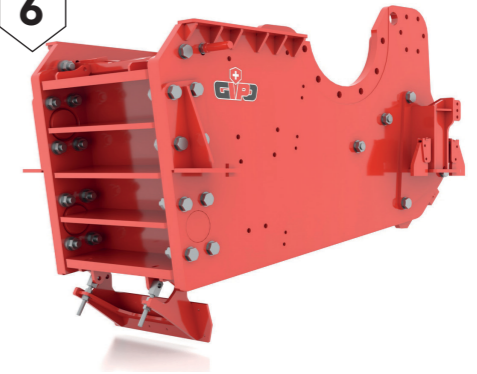

1

CRUSHER INLET

The crusher inlet and therefore the entire crushing chamber was designed for optimal material loading and high throughput. The material intake behaviour is optimised and material blockages avoided due to the correct relationship between the width and depth of the crushing chamber.

2

CRUSHING ARM BEARINGS

The eccentric shaft is manufactured from high-alloy heat-treated steel. Due to the use of large, high-quality, generously dimensioned bearings, a long service life is achieved along with low operating costs.

3

CRUSHING GAP ADJUSTMENT

The crushing gap at the crusher outlet can be regulated using the crushing gap adjustment. The robust, easy-to-service crushing gap adjustment is hydraulic with proven, rigid spacer support. Its integrated thrust plate is used for overload protection to prevent damage in the crushing chamber.

4

CRUSHING ARM

The moving crushing arm is of high-quality welded construction. The optimised kinematic behaviour of the crushing arm, combined with an optimal stroke in the lower area of the crusher, aids throughput and crushing. The special arm design simplifies sustainable maintenance and servicing of the arm bearings.

5

CRUSHING JAW SUPPORT

The crushing jaw support ensures secure fastening and at the same time simplifies the replacement of the crushing jaw. Due to the design with screw-fastening, the crushing jaw support can be replaced quickly and straightforwardly if necessary due to wear.

6

CRUSHER HOUSING

Our crusher housings consist of a high-quality welded construction in a very robust design such that they can reliably withstand the highest loads and harsh application conditions for a long time.

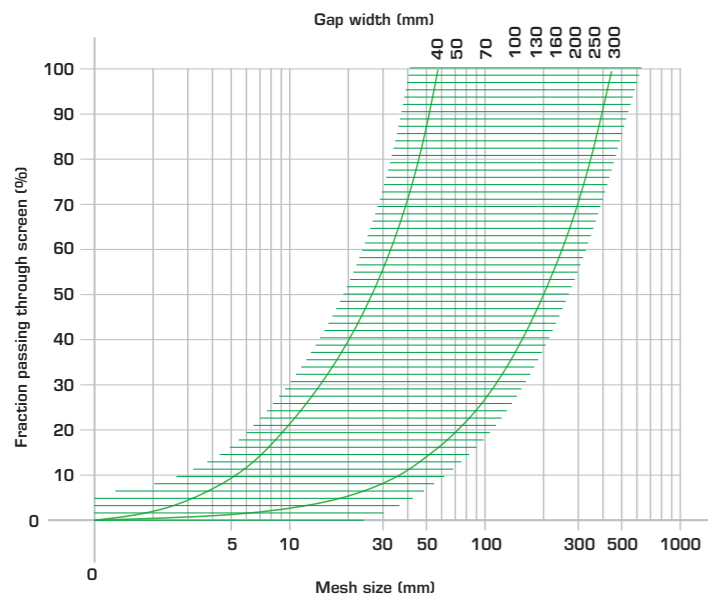
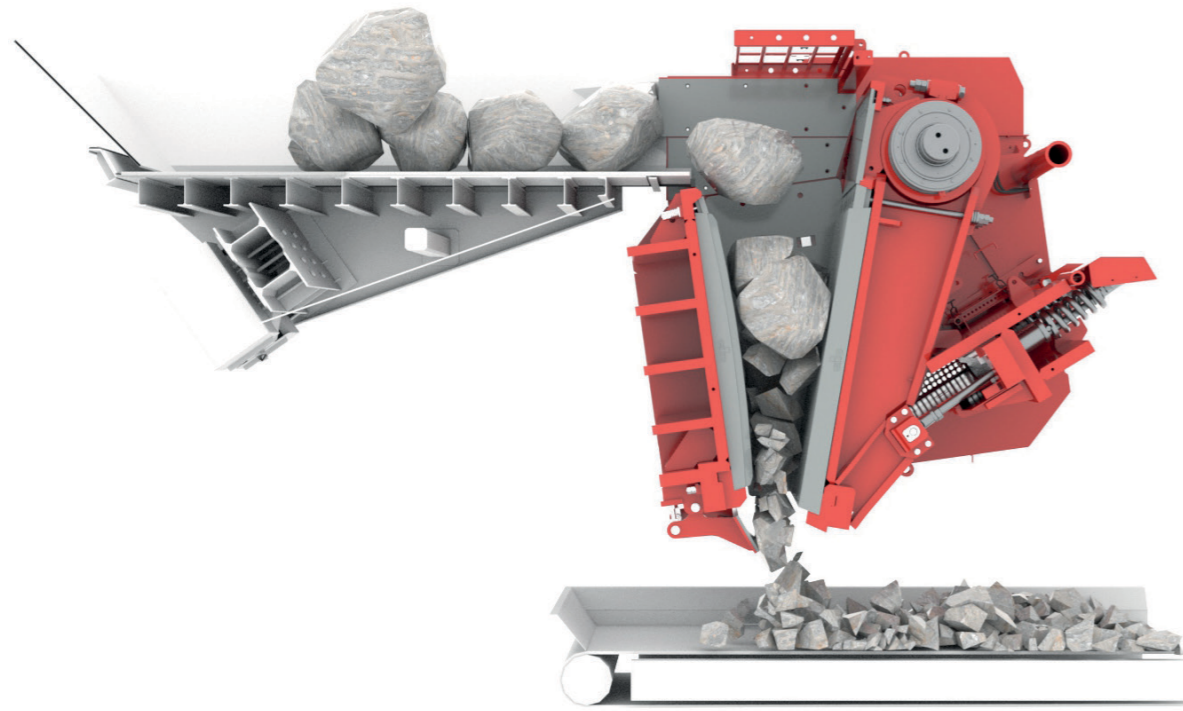

Primary crusher

- Pre-crusher for medium-hard to hard rock and minerals
- Suitable for large primary feed material
- Generously dimensioned design

Screening curve: The particle distribution is dependent on the feed material (feed material lump size, particle size distribution/portion of fine material), discharge of pre-screen material, the required final particle size, optimal operation of the plant and feeding, as well as the correct adjustment of the plant.

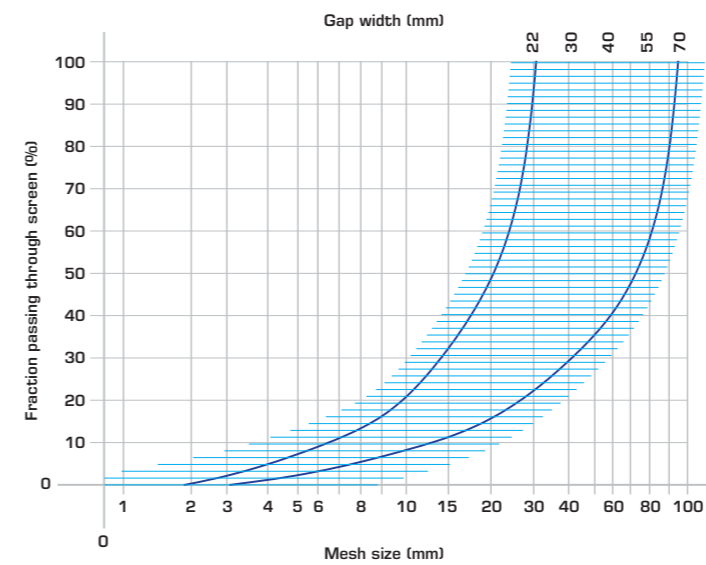

Secondary crusher

- Post-crusher for hard, abrasive feed material
- Production of ballast and chippings
- Suitable for medium-sized secondary feed material
- Compact design
- Cubic end product

Screening curve: The particle distribution is dependent on the feed material (feed material lump size, particle size distribution/portion of fine material), discharge of pre-screen material, the required final particle size, optimal operation of the plant and feeding, as well as the correct adjustment of the plant.

CRUSHING BEHAVIOUR

Various settings on the GIPO jaw crusher can be used to change the particle size distribution. The crushing gap adjustment and the selection of the crushing jaws can have a significant effect on the crushing curve for the end product. GIPO AG also offers a variety of proven crushing jaws for fitting to the fixed crushing wall and the crushing arm. The continuous adjustment of the crusher speed helps you to produce the product required in every application.

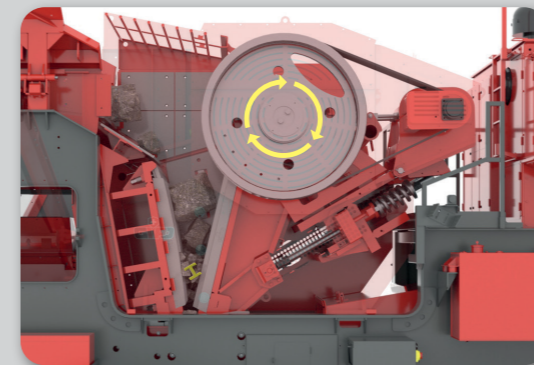

REVERSING

During operation in reverse, the arm is moved in the opposite direction. It is very easy to remove blockages or clogging in the crushing chamber with the aid of the reversing function.







CRUSHING JAWS

We have various models of crushing jaws for different applications. All models are made of high-alloy wear-resistant steel. The crushing jaws are quick and straightforward to change due to the simple fastening. Optimised tooth profiles and crushing jaw thicknesses as well as the optimal quality of the wear-resistant steel make possible maximum material throughput with minimum operating costs.

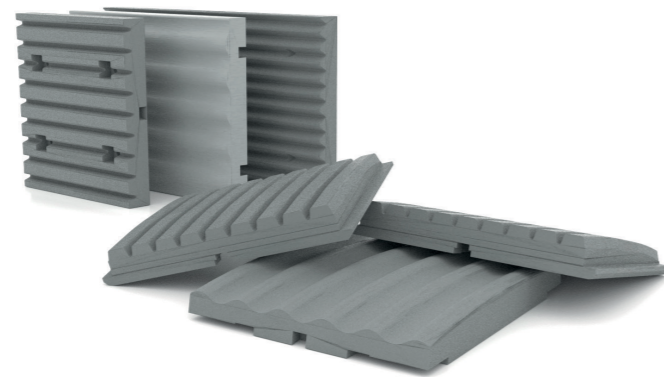

Other tooth profiles and alloys available. For more information, please contact your GIPO representative.



SHAPE TYPE	CHARACTERISTICS
POINTED SHAPE (STANDARD) 	<ul style="list-style-type: none"> - Recommended for round material and non-abrasive rock - Reduction of the flaky portion - Ideal tooth spacing for the removal of fine portions - Good material acquisition - Reduced service life with abrasive material - Recommended for small feed sizes and gap widths
TRAPEZOID SHAPE (QUARRY) 	<ul style="list-style-type: none"> - Recommended for abrasive rock and/or rock extracted by blasting - Increased service life due to the flat profile - Higher load and performance requirement
WAVE SHAPE 	<ul style="list-style-type: none"> - Recommended for building rubble/recycling - Less material adhesion - High throughput



TECHNICAL DATA SHEET

Jaw crusher	Inlet opening (WxH) approx. (mm)	Gap width approx. (mm)	Eccentric speed approx. (rev./min)	Throughput up to (t/h)	Final particle size approx. (mm)	Total weight approx. (t)	Operating weight (incl. drive) approx. (t)
B 0850	810x500	40-130	250	250	0-150	13.5	14.5
B 0960	900x600	40-160	250	400	0-200	12.0	13.5
B 1170	1,120x680	40-200	250	510	0-260	20.5	22.5
B 1270	1,200x720	40-200	280	550	0-260	26.0	28.0
B 1290	1,130x900	80-200	250	540	0-260	30.0	33.0
B 1470	1,330x680	70-200	250	600	0-260	29.0	31.5
B 1490	1,330x900	80-220	240	710	0-300	33.5	36.0
B 14100	1,324x1,000	100-250	235	760	0-320	48.5	52.0
B 14120	1,400x1,250	120-250	220	800	0-320	78.0	82.0
NB 0625	600x200	20-60	240	40	0-55	4.5	5.0
NB 1035	1,065x350	30-85	285	100	0-80	14.5	16.0

Jaw crusher	External height A approx. (mm)	External width B approx. (mm)	External length C approx. (mm)
B 0850	2,250	1,500	2,700
B 0960	2,400	1,700	2,400
B 1170	2,700	2,100	2,800
B 1270	2,400	2,700	3,100
B 1290	3,300	2,300	3,400
B 1470	2,900	2,500	3,300
B 1490	3,300	2,500	3,400
B 14100	3,500	2,900	4,000
B 14120	4,000	3,200	4,200
NB 0625	1,400	1,400	1,900
NB 1035	1,900	2,000	2,400

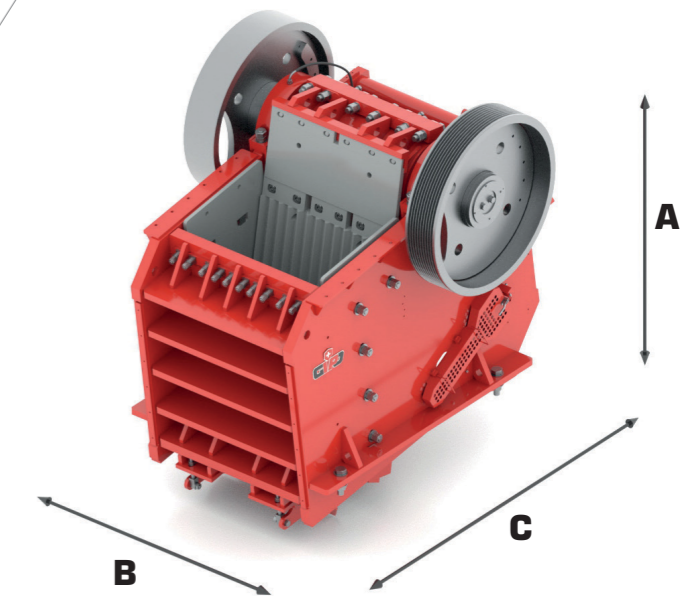

The values stated in relation to the crushing performance, feed performance and feed material lump size are heavily dependent on the characteristics of the feed material (condition/abrasiveness, particle size distribution, portion of fine material, etc.), the required final particle size, optimal operation of the plant and feeding, as well as the correct adjustment of the plant.

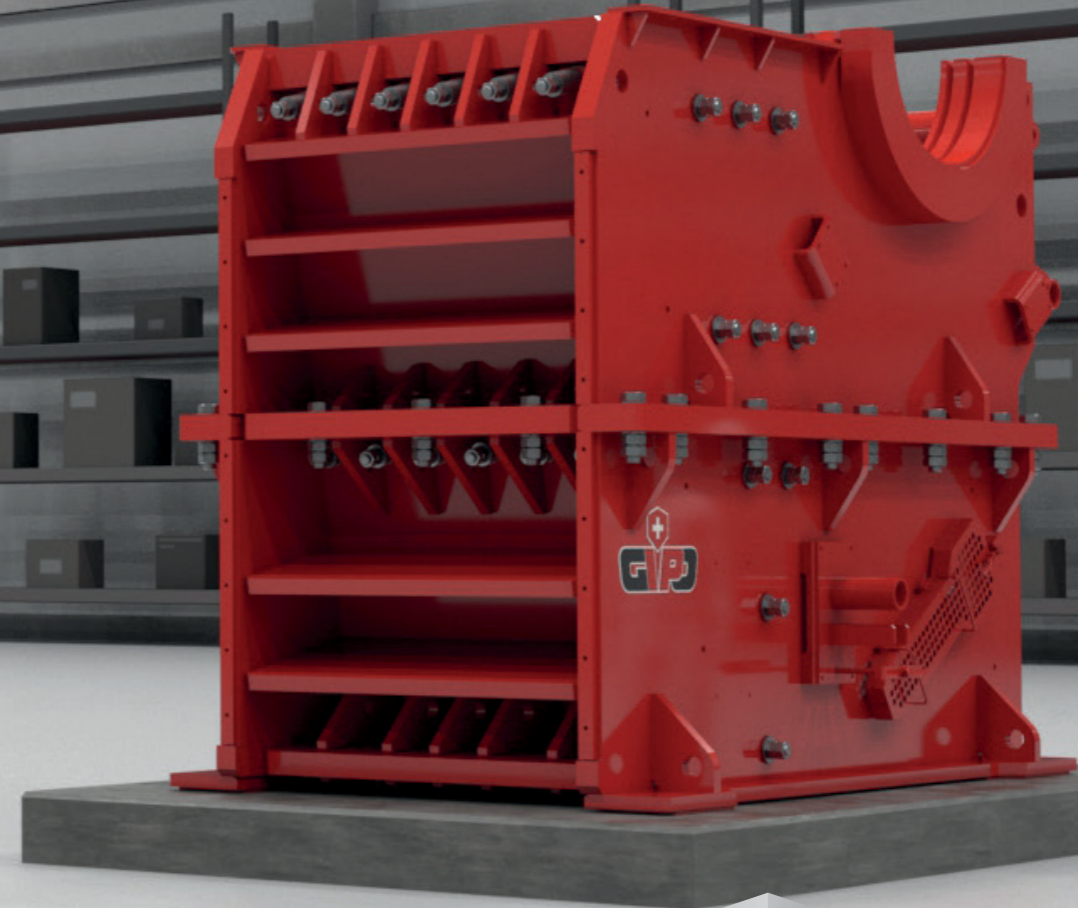
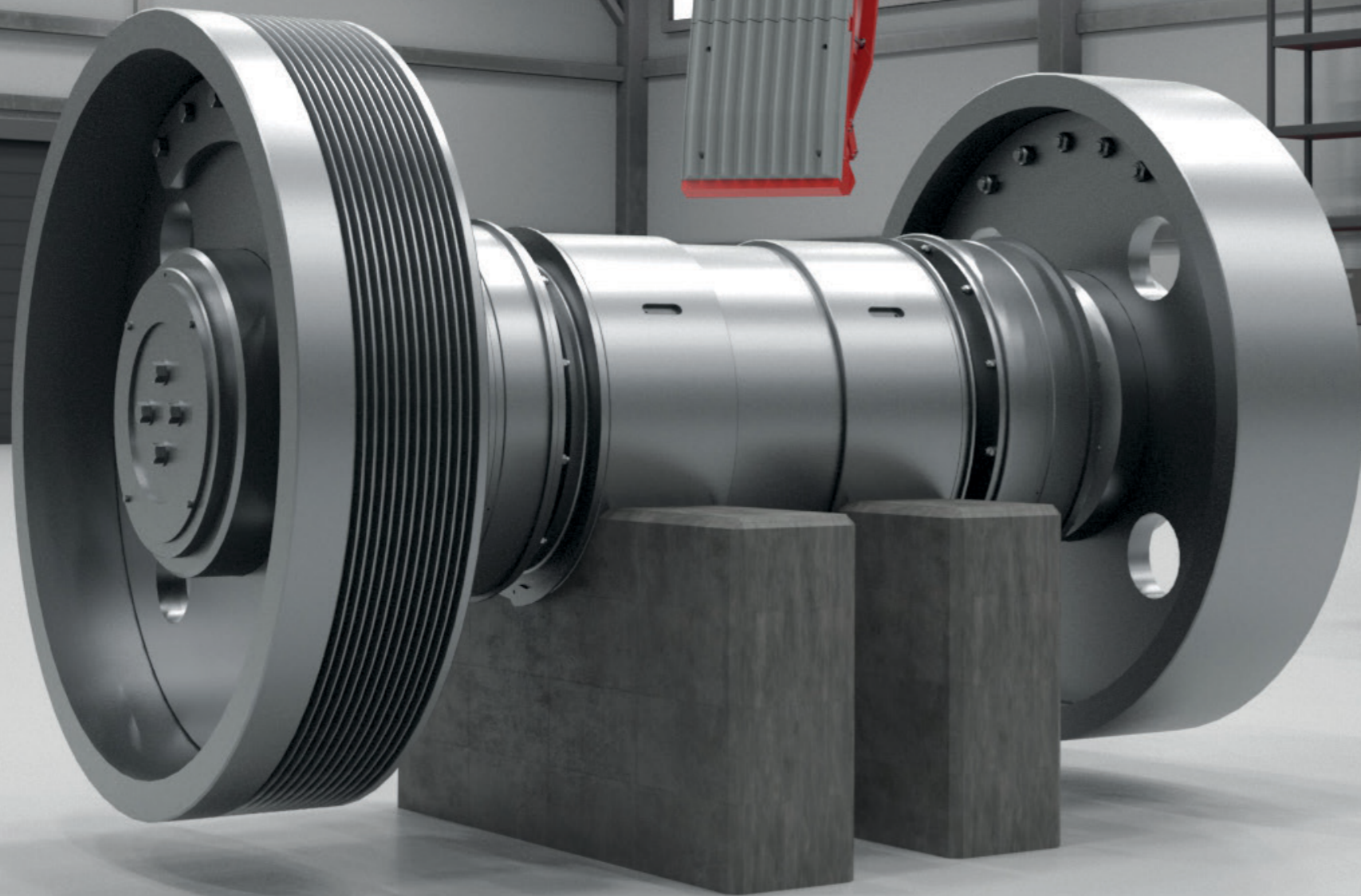

“ **REVOLUTIONARY DESIGNS
AND ASSEMBLIES FROM URI** ”



GIPO AG
Industriegebiet See, Zone C
Kohlplatzstrasse 15
CH-6462 Seedorf

T +41 41 874 81 10
info@gipo.ch
www.gipo.ch
Schweiz / Switzerland / Suisse



Figures and text are for information only and may include options. Subject to technical change. Performance data are dependent on the application conditions.