

SWISS POWER

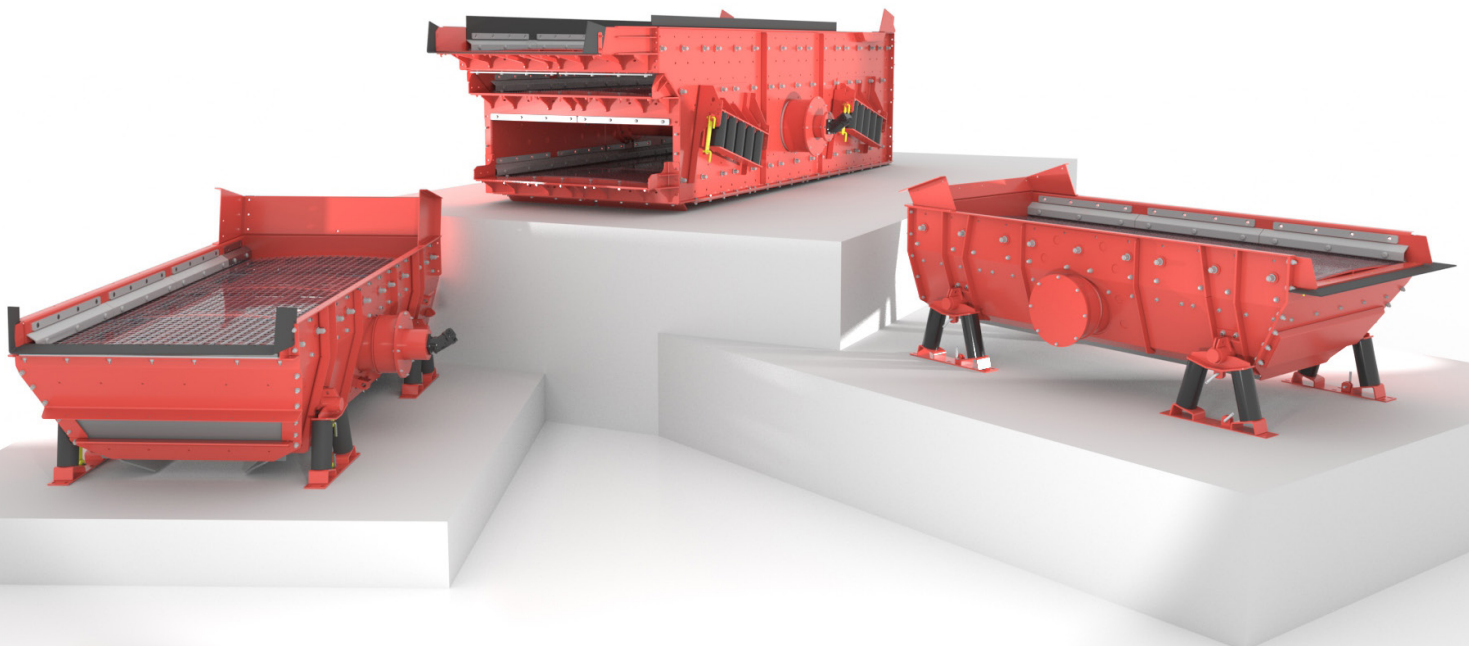

**CLASSIFIER FINAL SCREENING
MACHINE**



FINAL SCREENING MACHINE – OPTIMAL CLASSIFICATION



Our final screening machines, further developed over many years, impress with their high screening performance as well as individual modifications to suit customer wishes. Whether the issue is the classification of natural stone, the screening of limestone or the separation of recycled material, their versatility is almost unlimited. Each of these application areas and many others require screens specially combined for you. We manufacture your individually configured final screening machine to suit your feed material and leave nothing to be desired.

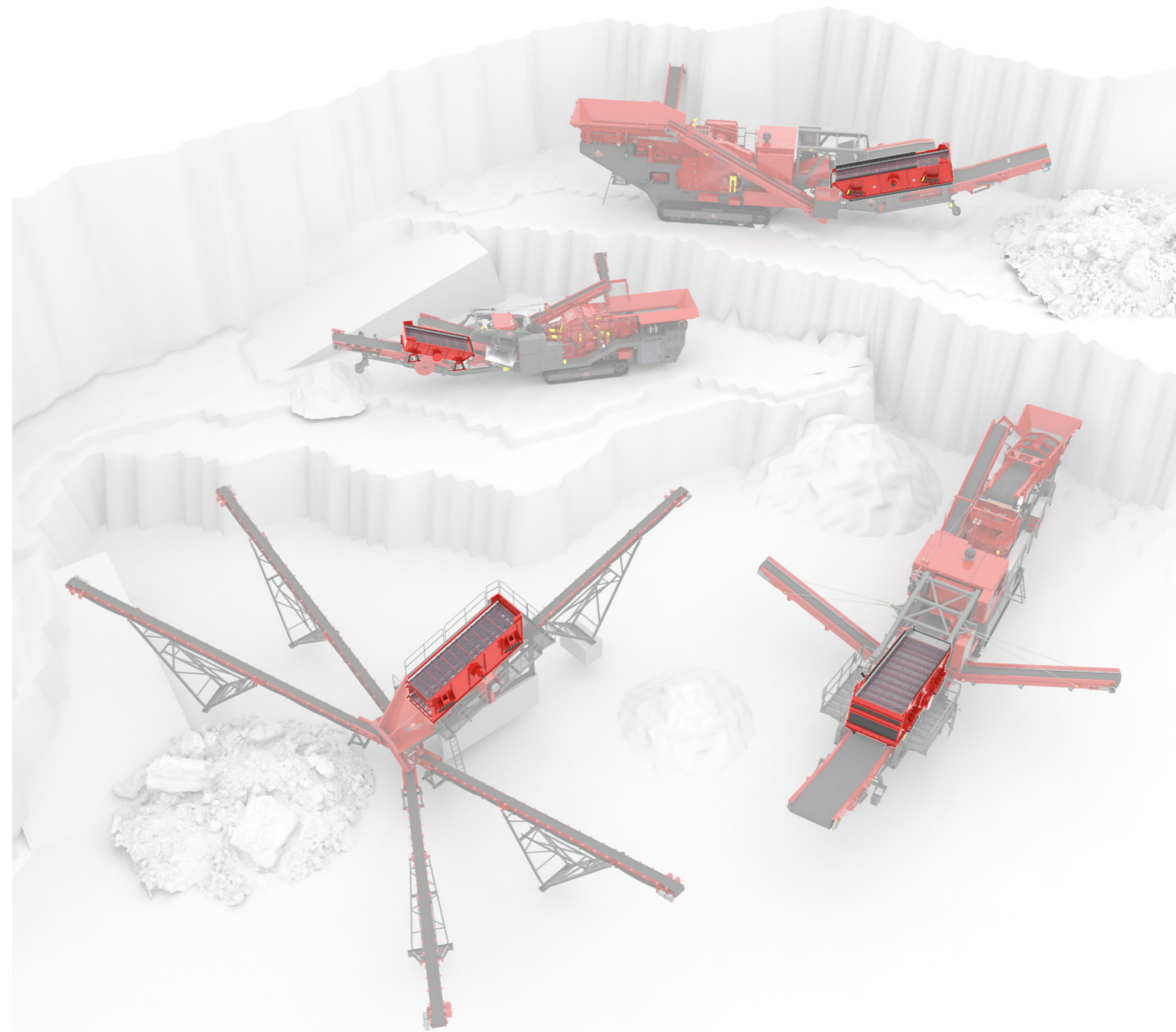
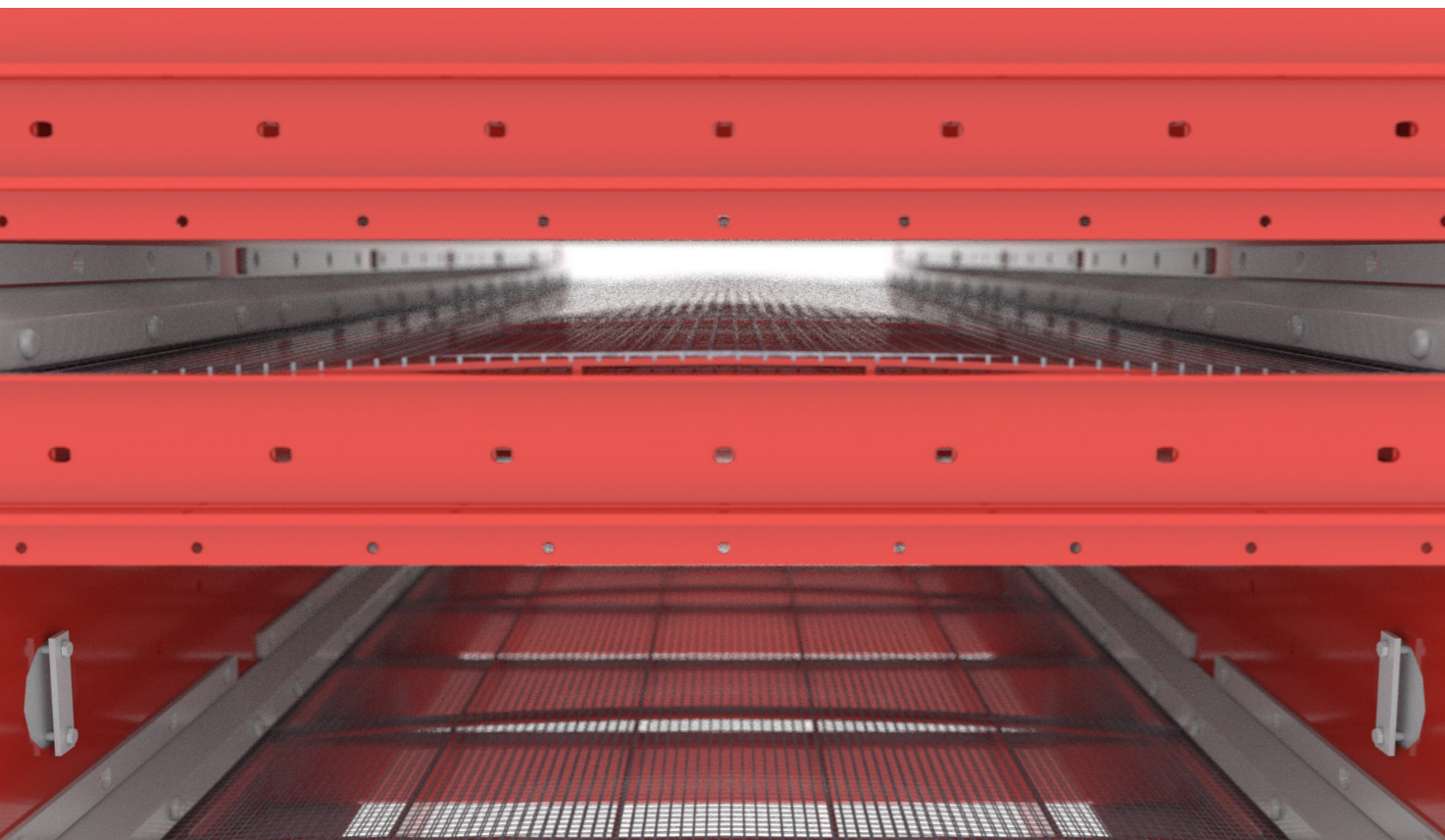

“ **INDIVIDUAL FINAL SCREENING
MACHINE TO SUIT YOUR WISHES** ”

RELIABLE – EFFICIENT – FLEXIBLE

The generously designed screen areas ensure high screen performance as well as optimal screening of the feed material. By means of different deck variants (1 to 3 decks), a wide range of dimensions, as well as bespoke manufacture, we will find the right product for you.

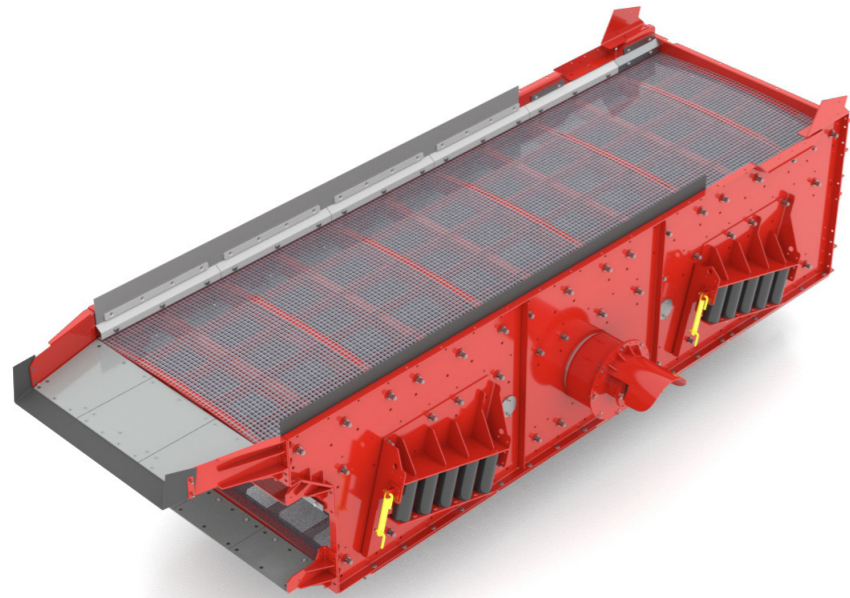

“IMPRESSIVE FINAL SCREENING MACHINES”

Our extensive experience and advanced production processes make possible high-quality final screening machines.



JANEK METTLER
HEAD OF PLANT MANUFACTURE
GIPO AG

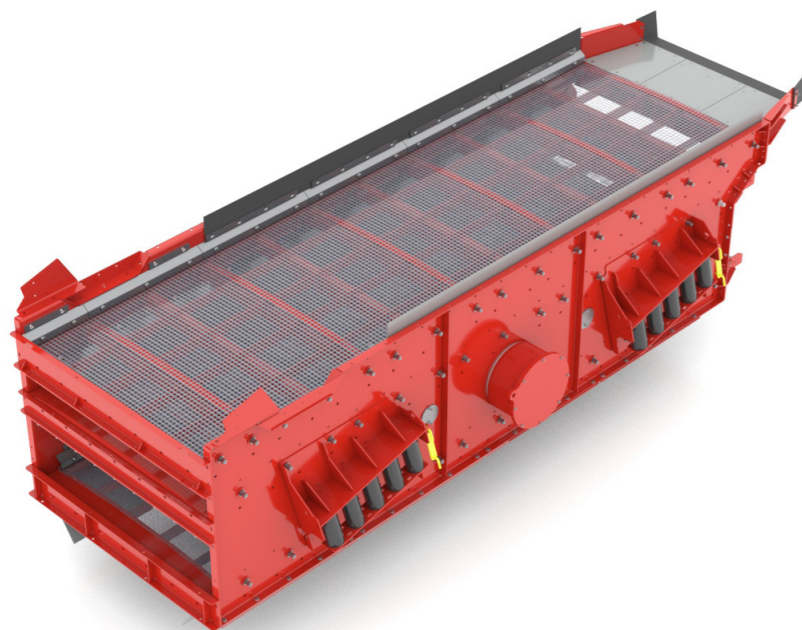

MAIN FEATURES

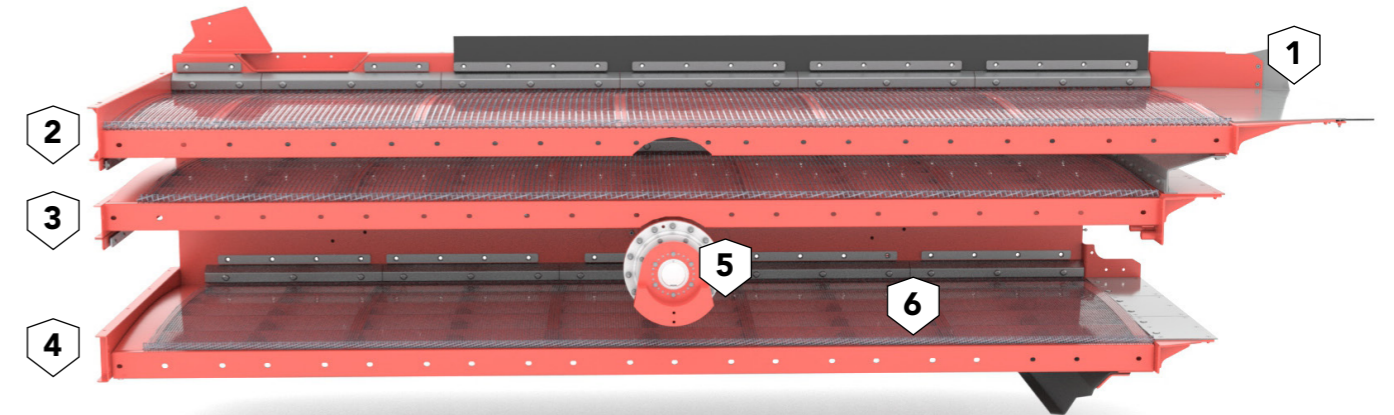

WORLD-CLASS FINAL SCREENING MACHINES

Our world-renowned final screening machines offer optimal screen quality, individuality, excellent reliability and unique performance. In this way it is ensured that even the most difficult materials are classified to your requirements. From a 1-deck to a 3-deck final screening machine, using which up to four classifications can be produced, nothing is left to be desired.

1

WEARING PLATE

With numerous material thicknesses and a broad spectrum of qualities, GIPO AG offers maximum efficiency.

2

UPPER DECK

The upper deck separates the oversize material from the feed material; this oversize material is transported to the material return.

3

MIDDLE DECK

The material that does not fall through the middle deck is transported to the heap using a conveyor belt.

4

LOWER DECK

The lower deck can classify up to four fractions. The material that falls through the screen gratings is transported to the heap using the conveyor under the screen.

5

ECCENTRIC DRIVE

With the circular, oscillatory motion, the eccentric drive transports all types of feed materials.

6

SCREEN CONFIGURATION

The configuration of the screening machines is selected to suit the feed material so as to obtain an efficient result.

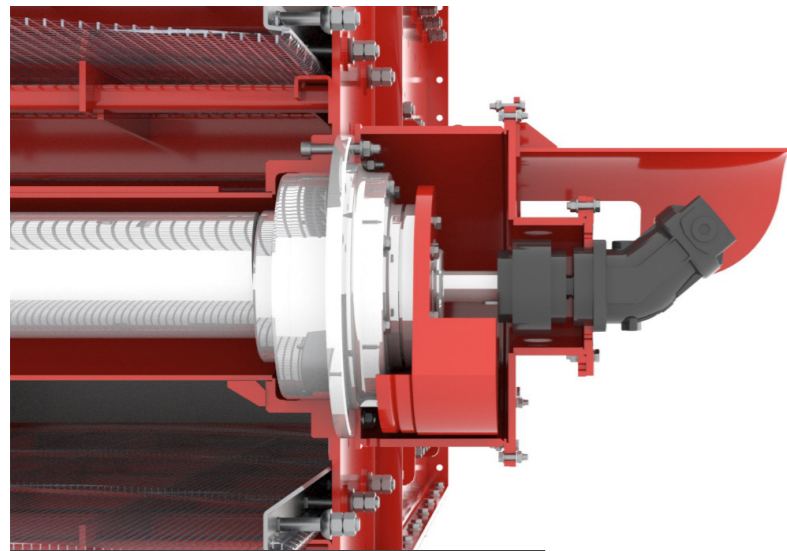

IMBALANCE DRIVE
HYDRAULICALLY POWERED

ADJUSTING THE WEIGHTS CHANGES THE MAGNITUDE OF THE VIBRATION AND THE ACCELERATION OF THE MATERIAL. IN THIS WAY, FOR INSTANCE, CLOGGING CAN BE CONTROLLED.

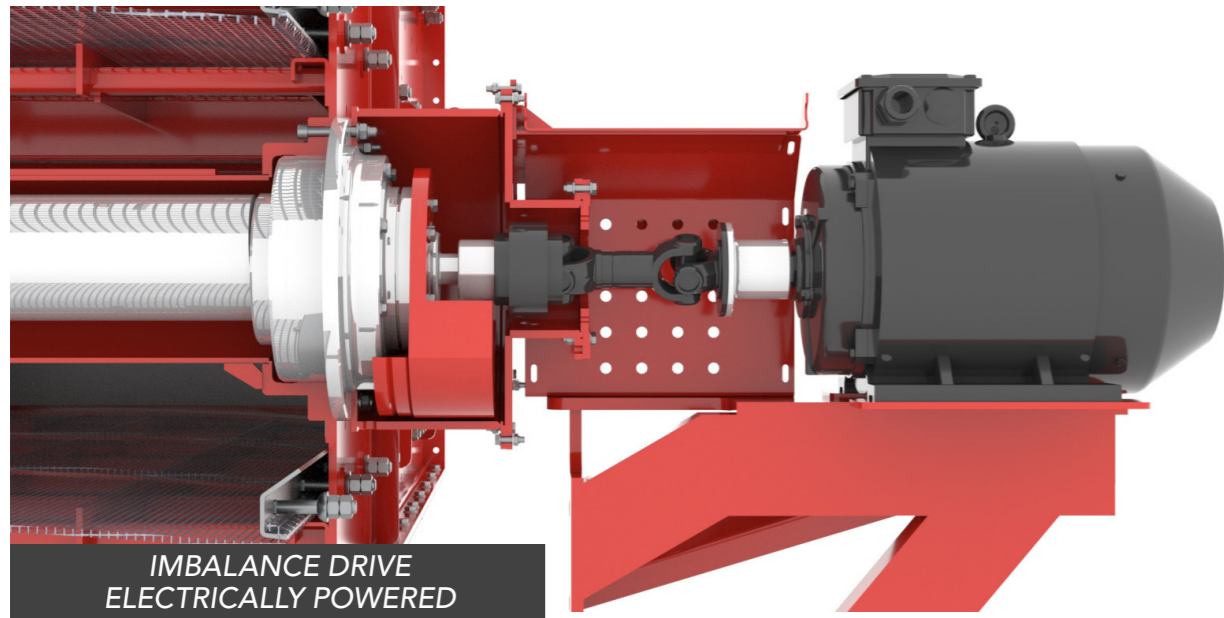

IMBALANCE DRIVE
ELECTRICALLY POWERED

DRIVE VARIANTS

The hydraulically or electrically powered imbalance drive conveys the feed material. The imbalance drive consists of a solid shaft and the imbalance weights attached to the ends. Adjusting the weights changes the magnitude of the vibration and the acceleration of the material. In this way, for instance, clogging can be controlled.

SCREEN CONFIGURATION VARIANTS

The robust screens used by GIPO AG allow cost-effective, reliable separation of the feed material. Metal and plastic screens are used; the screens are selected to suit the application. The types of screen covering and fastening are agreed with the customer and matched to the crushed material to ensure a highly flexible screening result as well as excellent ease of use.

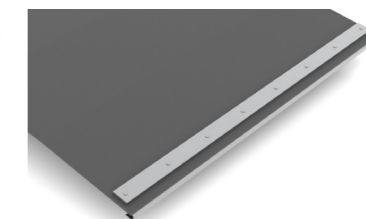
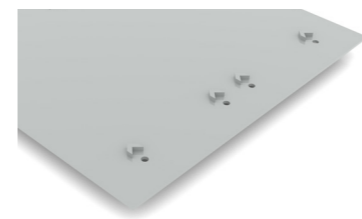
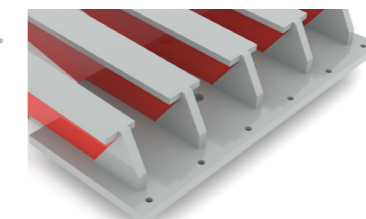
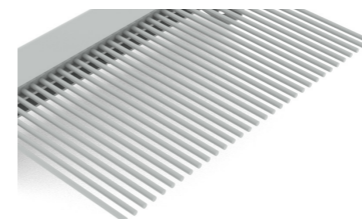
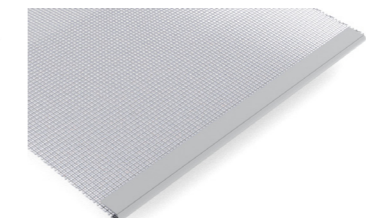
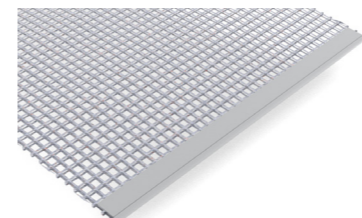
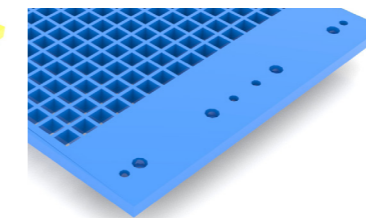
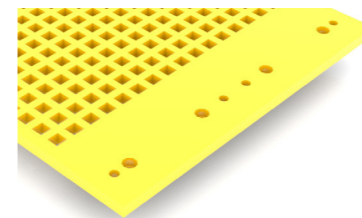
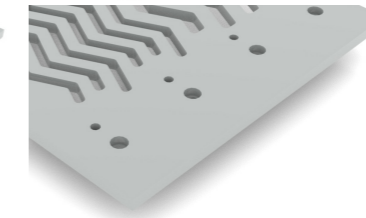
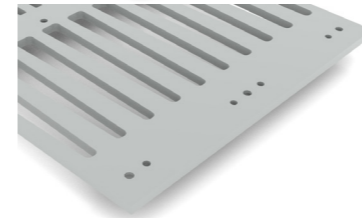
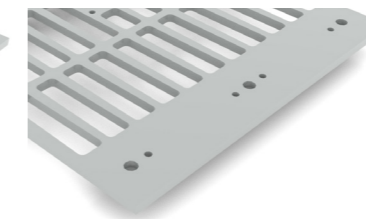
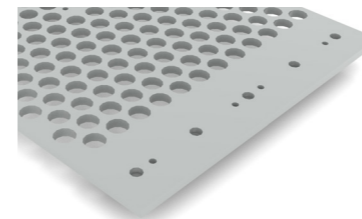

ROUND PUNCH PLATE

The correct selection of the round punch plate is essential for efficient pre-screening. For this reason, we offer bespoke round punch plates manufactured to suit your needs and requirements exactly. We would be pleased to assist with correct selection.

PLASTIC SCREEN

The screens made of highly wear-resistant polyurethane are manufactured individually in a wide range of hardness ratings. Hole shape and size are designed to suit customer wishes.

SCREEN GRATING

Screen gratings are available in a wide range of versions and variants for the dry, damp and wet screening of crushed material.

GRIZZLY

A grizzly is recommended for the efficient processing of very glutinous feed material that would clog other screens.

BLANKING COVER

Blanking covers are available in a wide range of variants, from rubber to steel. The blanking cover can be used to bypass classification, i.e. the material is forwarded directly to the material flow.



WEARING PLATES

Highly wear-resistant plates are fitted to protect the final screening machine in areas subject to particularly high wear. Removal and replacement of the worn plates is straightforward. Alternatively, depending on the material conveyed or the application, it is possible to protect the highly exposed areas with wearing rubber. This protection prevents damage to the expensive screen housing.

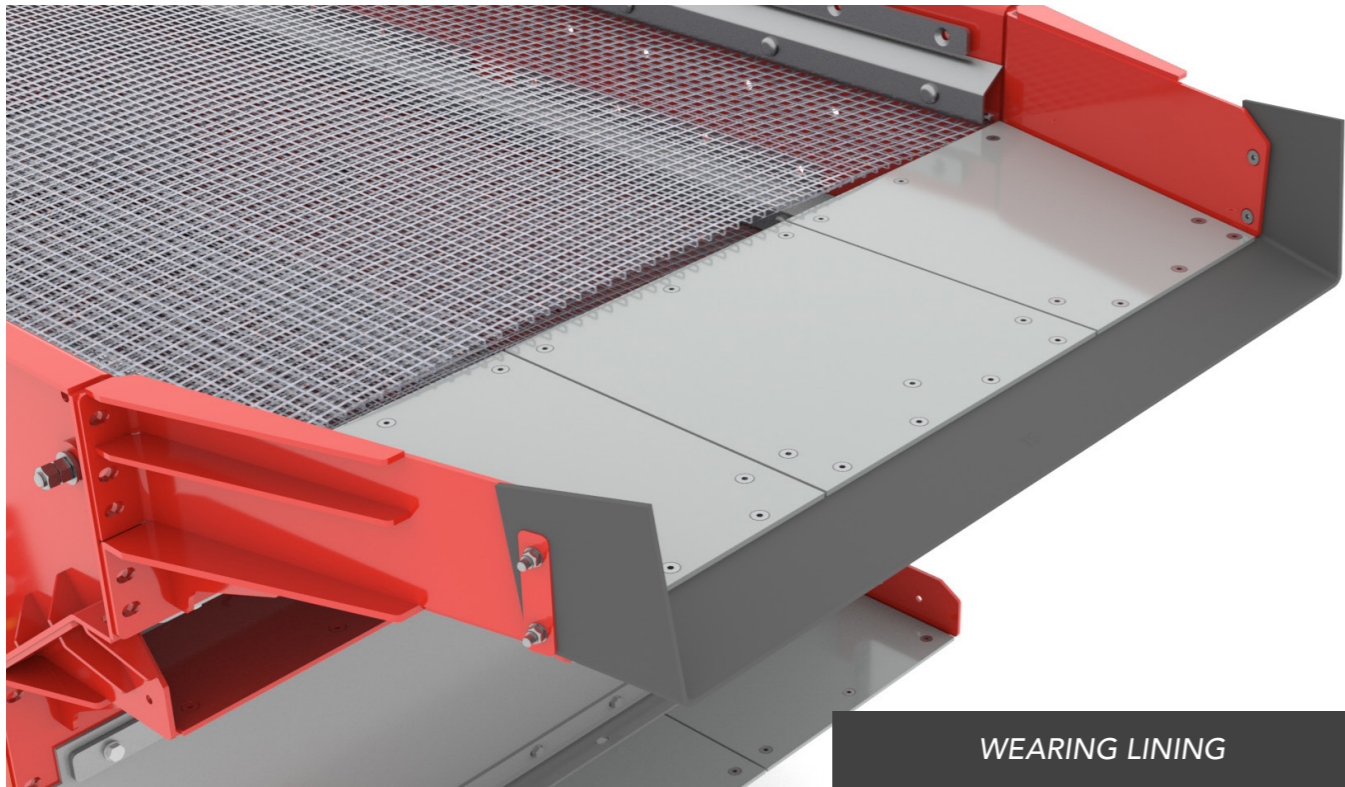

WEARING LINING

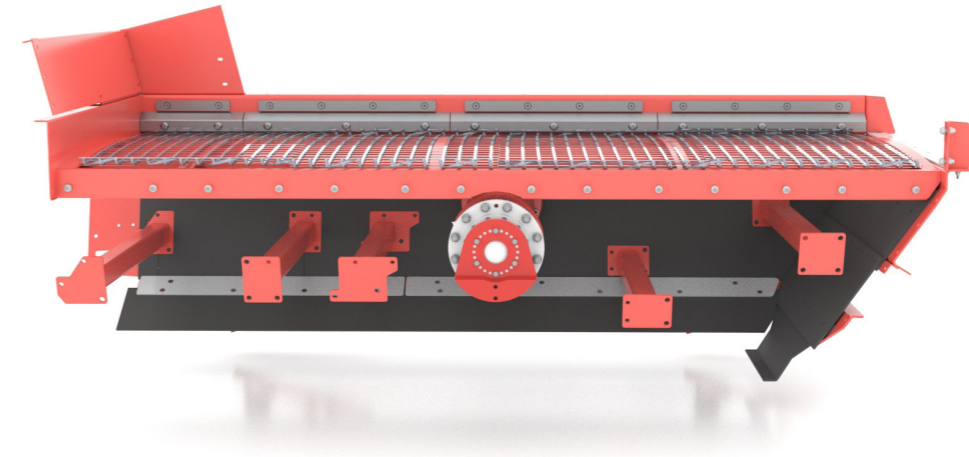

1-DECK SCREEN VARIANT

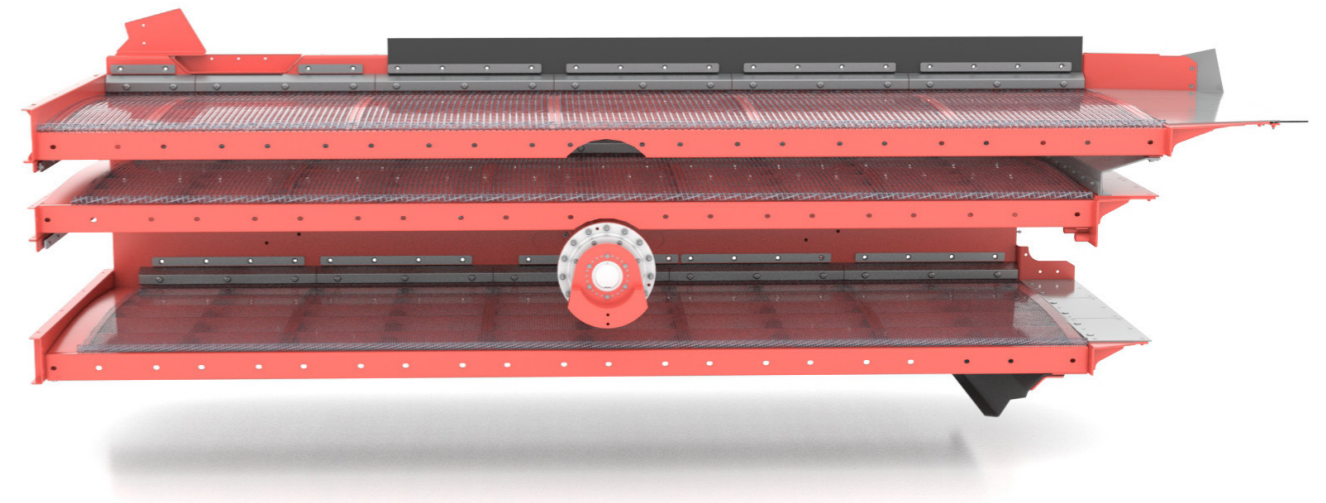

3-DECK SCREEN VARIANT

FASTENING VARIANTS, SCREEN GRATINGS

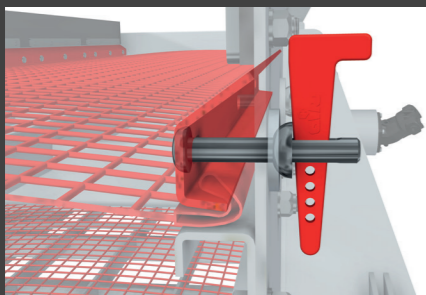

WEDGE FASTENING

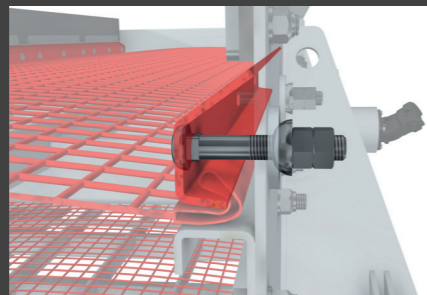

SCREW FASTENING

The robust screens used by GIPO AG allow cost-effective, reliable separation of the feed material. Metal and plastic screens are used; the screens are selected to suit the application. The types of screen covering and fastening are agreed with the customer and matched to the crushed material to ensure a highly flexible screening result as well as excellent ease of use.

SCREEN DECK (1 TO 3-DECK VERSION)

From the small 1-deck to the 3-deck final screening machine, we offer the appropriate solution for all application areas. Here we are able to draw on extensive experience and use only high-quality products and materials for manufacture so that we deliver an efficient, robust final screening machine that meets your wishes.

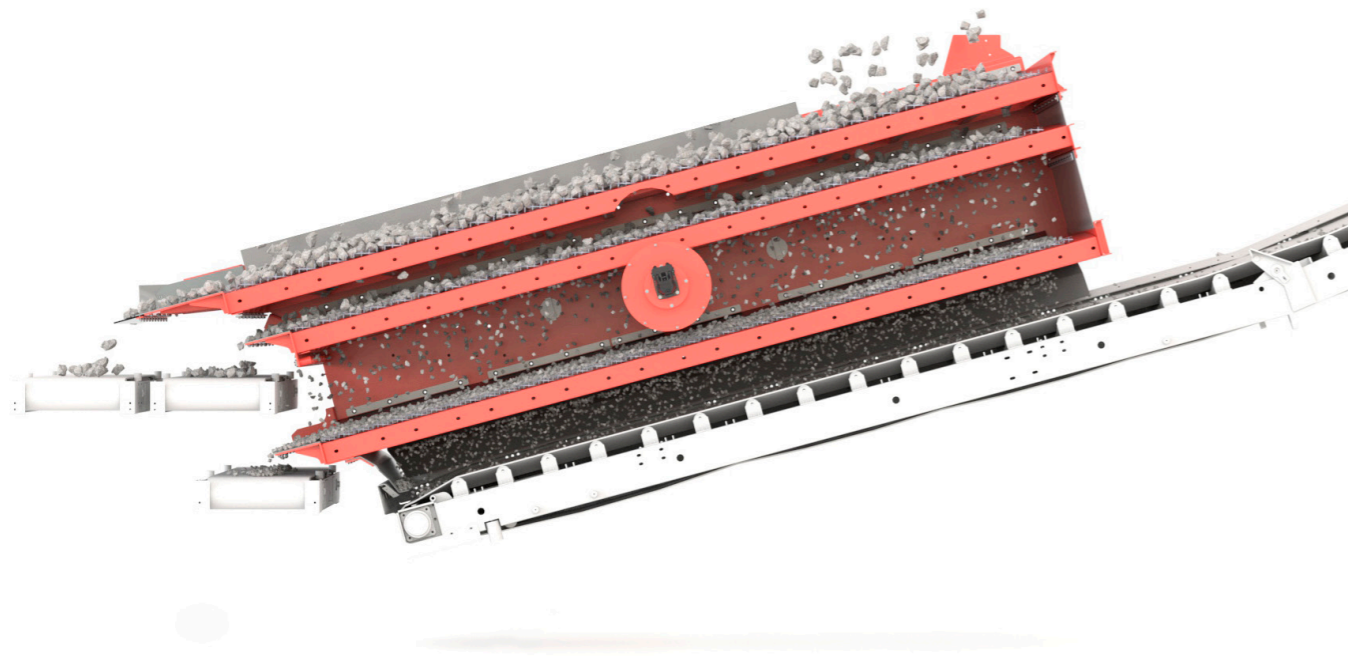

Final screening machine performance

With crushed particles
Approx. 20 % higher with round particles

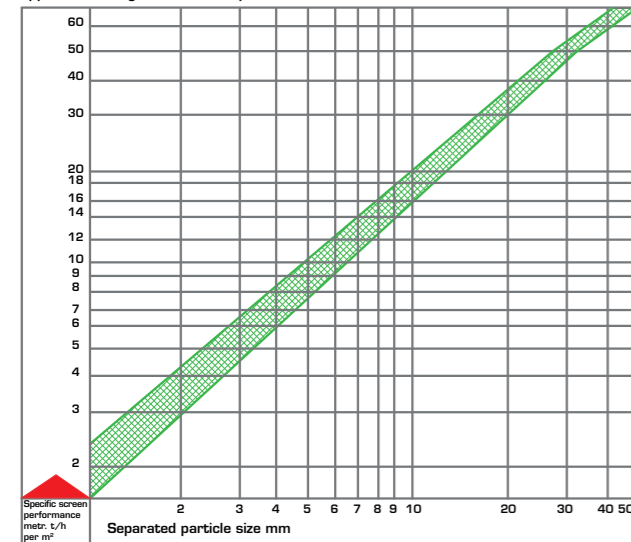

Final screening machine

- The screens are straightforward and quick to replace
- Powerful, efficient drive concepts
- Long service life
- Unique large screen areas

* Screening curve: The particle distribution is dependent on the feed material (feed material lump size, particle size distribution/portion of fine material), the required final particle size, optimal operation and feeding, as well as the correct adjustment of the plant.

FINAL SCREENING MACHINE PERFORMANCE

The performance of a final screening machine depends on many factors, e.g. the size and characteristics of the screen mesh, the intensity of the vibration and the nature of the material to be screened. An effective final screening machine can process large quantities of material in a short time and achieve high separation performance. It can also contribute to the improvement of the quality of the end product by removing impurities and ensuring a consistent particle size distribution. Also, with a high-performance final screening machine, it is possible to improve the productivity and efficiency of production processes because the material consumption and the effort required can be reduced.

TECHNICAL DATA SHEET

Final screening machine	Useful width NB Upper deck approx. (mm)	Useful length NL Upper deck approx. (mm)	Useful width NB Lower deck approx. (mm)	Useful length NL Lower deck approx. (mm)	Imbalance drive	Total weight approx. (t)	External length A approx. (mm)	External width B approx. (mm)	External height C approx. (mm)	Screen inclination approx. (°)
NS 1330-1	1,300	3,000	-	-	UWL 215	2.1	3,300	2,100	1,450	20
NS 1535-1	1,540	3,500	-	-	UWL 215	2.1	3,950	1,800	1,600	18
NS 1535-30-2	1,540	3,500	1,540	3,000	UWL 215	3.0	3,950	1,800	1,600	18
NS 1550-45-2	1,550	5,000	1,550	4,500	UWL 300 +	4.4	5,300	2,500	1,350	15
NS 1555-50-2	1,550	5,500	1,550	5,000	UWL 300 +	4.6	6,400	2,500	2,150	15
NS 1555-50-3	1,550	5,500	1,550	5,000	UWL 300 +	6.4	6,400	2,500	2,150	15
NS 1855-50-2	1,800	5,500	1,800	5,000	UWL 300 +	4.7	6,200	2,800	2,050	15
NS 1855-50-3	1,800	5,500	1,800	5,000	UWL 300 +	6.8	6,200	2,800	2,050	15
NS 1865-60-2	1,800	6,500	1,800	6,000	UWL 360	5.7	7,350	2,850	2,050	15
NS 1865-60-3	1,800	6,500	1,800	6,000	UWL 360	8.1	7,200	2,850	2,050	15
NS 2055-50-2	2,000	5,500	2,000	5,000	UWL 300 +	5.5	5,900	2,950	1,650	15
NS 2065-60-2	2,000	6,500	2,000	6,000	UWL 360	7.4	7,200	3,050	1,850	15

Tensioned screens are fitted to the screening machine crosswise or longitudinally, depending on the design, using a tensioning device. Along with our standard sizes, which are matched to downstream components from GIPO AG in the processing chain, we can also manufacture bespoke designs. The length can be manufactured to customer requirements.

* The drive power is designed to suit the length, installation position and feed hopper capacity.

** The total weight may vary depending on the length.

Dimension **A** is designed to suit the application or as required.

Dimension **B** may vary depending on the width of the support and is designed correspondingly.

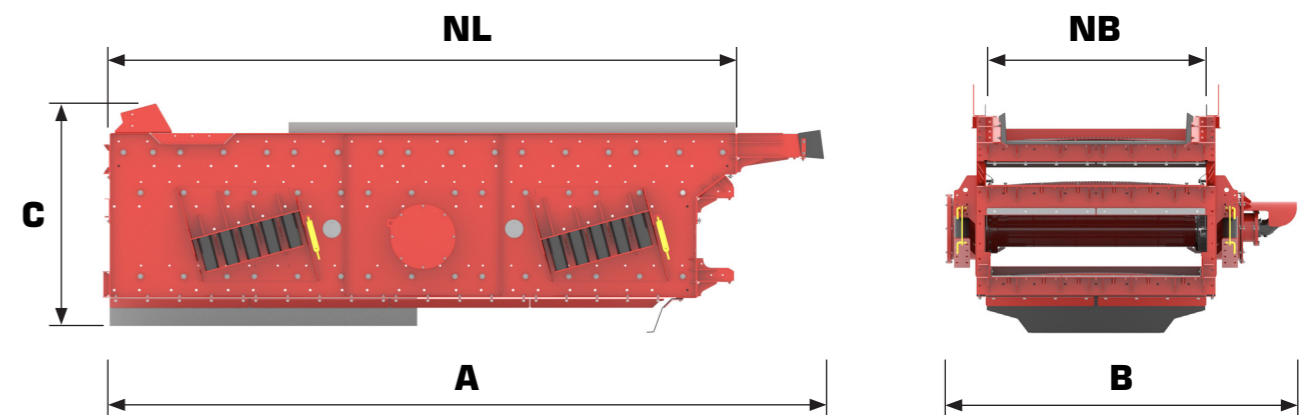

* The values stated in relation to the crushing performance and feed material lump size are heavily dependent on the characteristics of the feed material (condition/abrasiveness, particle size distribution, portion of fine material, etc.), the required final particle size, optimal operation of the plant and feeding, as well as the correct adjustment of the plant.



GIPO AG
Industriegebiet See, Zone C
Kohlplatzstrasse 15
CH-6462 Seedorf

T +41 41 874 81 10
info@gipo.ch
www.gipo.ch
Schweiz / Switzerland / Suisse



Figures and text are for information only and may include options.
Subject to technical change. Performance data are dependent on
the application conditions.